

INSTALLATION INSTRUCTIONS FOR M91P RIM EXIT DEVICE

999-30127

DOOR HANDING

OUTSIDE OF DOOR

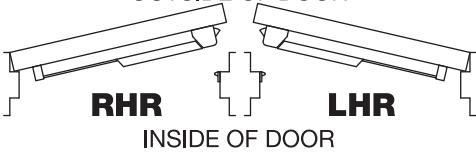

PANIC BAR SPECIFICATIONS

Door Thickness Range	1-3/4" – 2-1/4"	UL	UL305
Door Width Maximum (No modification)	36"	ANSI A156.3	Grade 1
Door Width Minimum with Cutting Single Door	28"	ADA	Compliant
Door Width Minimum with Cutting Double Door with Mullion	30"	Latch Bolt Throw	3/4"
		Cylinder	SC4 (6 pin)
		Dogging	Yes



**QUESTIONS? CALL
1-866-LOCK-PRO
(1-866-562-5776)
FOR HELP.**

Left Hand Reverse (LHR) orientation is shown below. Right Hand Reverse (RHR) is opposite.

NOTE 1: For doors less than 36" wide, see Appendix A for cutting the unit to the correct length.

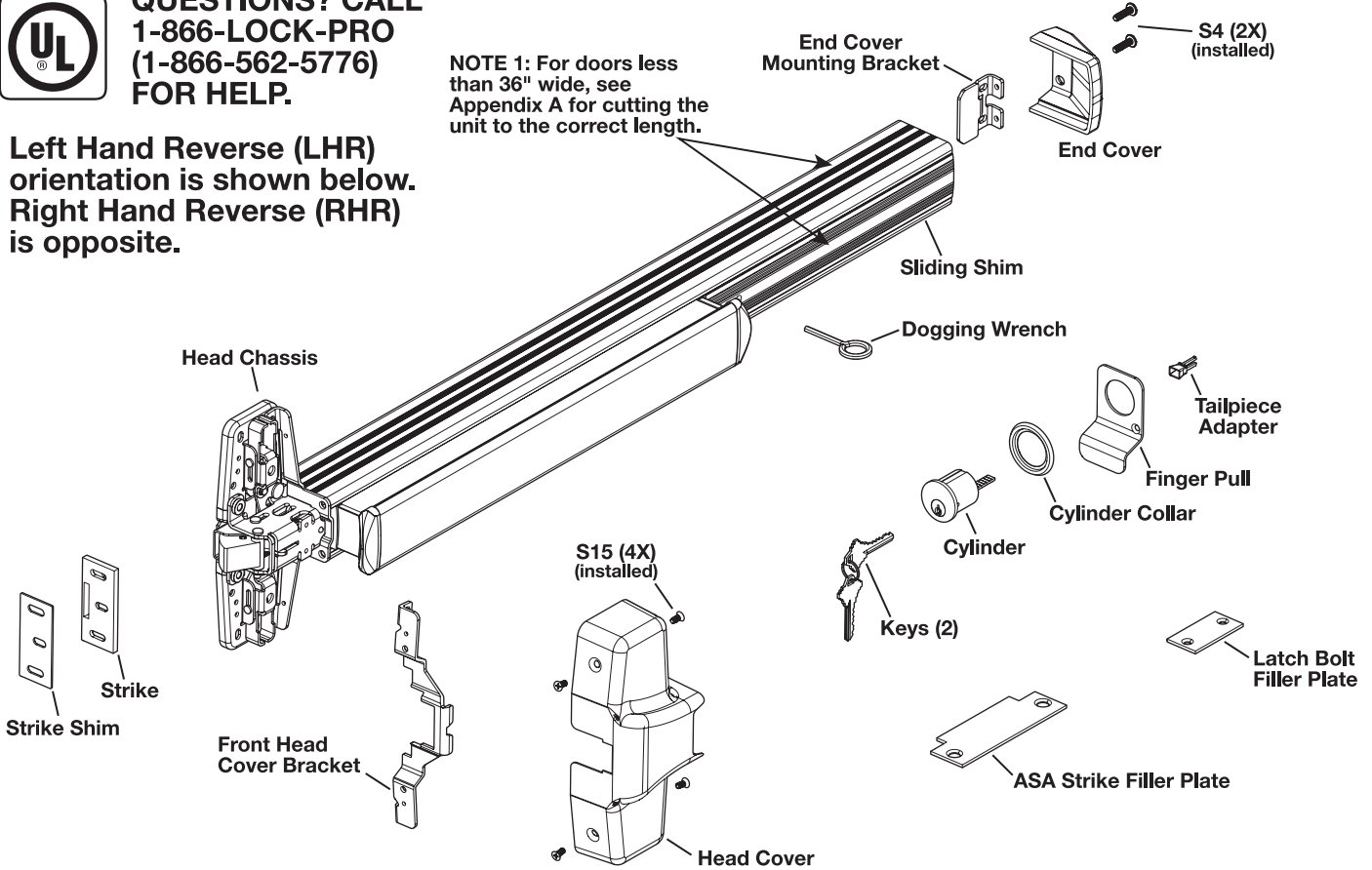

For steel prepared doors, drill/tap and use supplied machine screws. For thin gauge metal, non-prepared doors and wood doors, use self-tapping screws.

TOOLS REQUIRED

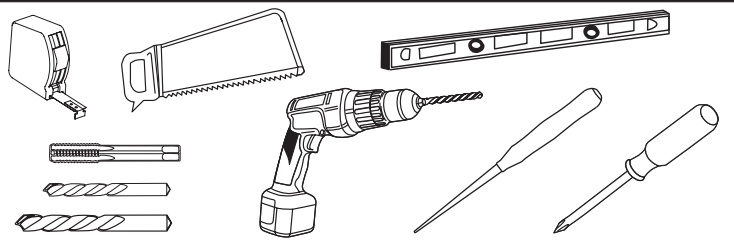

METAL

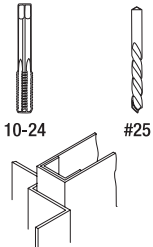

WOOD OR THIN GAUGE METAL

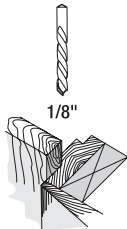



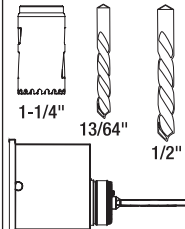



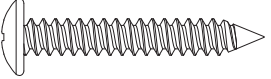

CYLINDER OPTION

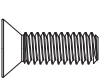
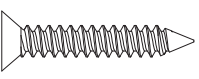
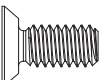
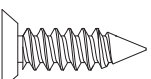
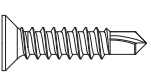

SCREW TABLE FOR M91P RIM EXIT DEVICE

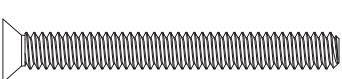
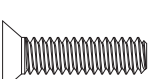
(see template 999-300128 and Appendices B & C for additional information)

	DESCRIPTION		QTY	WHERE USED	IMAGE 1:1 SCALE
	DOOR THICKNESS	DOOR MATERIAL			
S1	Truss Head Self-Tapping Screw, #10 x 1-1/4"		6	Head Chassis	
			2	End Cover Bracket	
	1-3/4" - 2-1/4"	Wood or Metal			
S2	Truss Head Machine Screw, 10-24 x 1"		6	Head Chassis	
	1-3/4" - 2-1/4"	Metal			
S3	Truss Head Machine Screw, 10-24 x 1-1/2"		6	Head Chassis – used with through bolts	
	2-1/4"	Metal			
S4	Truss Head Machine Screw, 10-24 x 3/4"		2	End Cover Bracket	
			2	End Cover (installed)	
	1-3/4" - 2-1/4"	Metal			
S5	Truss Head Machine Screw, 10-24 x 1-1/4"		2	End Cover Bracket – used with through bolts	
	2-1/4"	Metal			
S6	Flat Head Machine Screw, 8-32 x 1/2"		2	Latch Filler Plate	
	N/A	Wood or Metal			
S7	Flat Head Self-Tapping Screw Screw, #8 x 1"		2	Latch Filler Plate	
	N/A	Wood or Metal			
S8	Flat Head Machine Screw, 12-24 x 1/2"		2	Strike Filler Plate	
	N/A	Wood or Metal			
S9	Flat Head Self-Tapping Screw, #12 x 3/4"		2	Strike Filler Plate	
	N/A	Wood or Metal			
S10	Flat Head Self-Drilling Screw, #8 x 3/4"		1	Finger Pull	
	N/A	Wood or Metal			
S11	Flat Head Machine Screw, 10-24 x 1-1/4"		2	Cylinder	
	1-3/4", 2"	N/A			
S12	Flat Head Machine Screw, 10-24 x 1-3/4"		2	Cylinder	
	2-1/4"	N/A			
S13	Flat Head Machine Screw, 10-24 x 3/4", Black		2	Strike Plate	
	N/A	Metal Jamb			
S14	Flat Head, #10 x 1-1/2" Self-Tapping Screw, Black		2	Strike Plate	
	N/A	Wood or Metal Jamb			
S15	Flat Head Machine Screw, 8-32 x 3/8"		4	Head Cover (Installed)	
	N/A	N/A			

TYPE OF INSTALLATION

A. RIM DEVICE ON SINGLE DOOR

New Installation: Measure from the door stop surface and floor.
 Replacement Installation: Use existing hole pattern if possible.
 Shim strike if necessary.

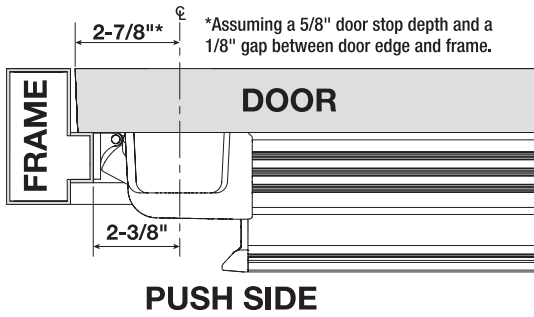

B. RIM x RIM x MULLION ON PAIR OF DOORS

New Installation: Measure from mullion side surface and floor.
 Replacement Installation: If strike is installed, use existing centerline.

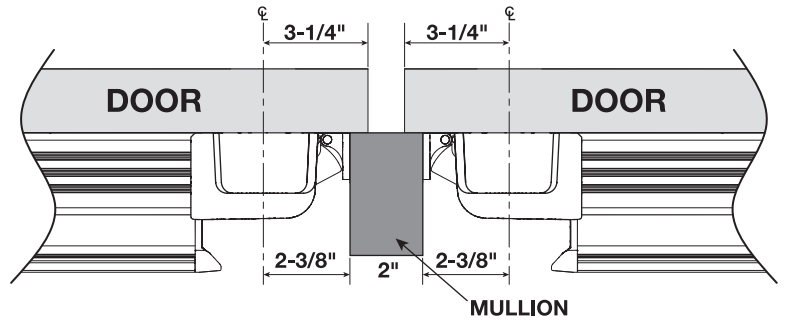

1 DRILL HOLES

- Determine if door is LHR or RHR. Cut out the appropriate section of template 999-30128 and fold it at the designated line.
- From the PUSH side of the door, first measure 40 inches from the floor and mark the door near the frame to establish the centerline.
- Place the provided template into position by using the small cutout window to align it with your indicated centerline, then secure with tape.
- Mark 6 holes for the head chassis and drill holes according to the type of door material and fastener required, being careful not to drill through the door.
- If the cylinder option is selected, see Appendix B for hole preparation and drilling instructions.

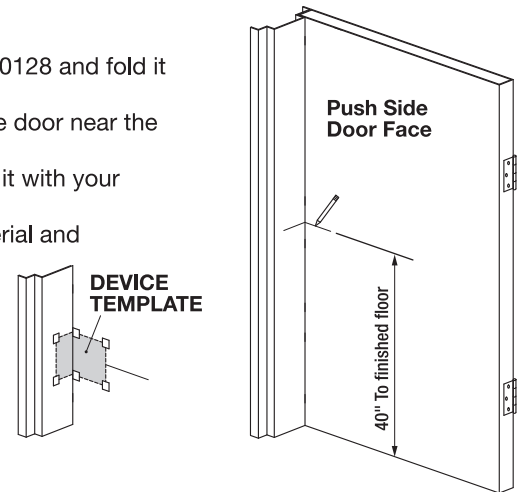

2 INSTALL CYLINDER (OPTIONAL)

- Insert the plastic tailpiece adapter into the tailpiece receptacle in the head chassis.
- Insert the cylinder and collar through the hole in the finger pull, and then into the prepared bore in the door.
- If necessary, cut the tailpiece to the approximate length extending about 1/2 inch from the door face.
- Insert the two S11 or S12 (see table) machine screws through the holes on the PUSH side of door to secure the cylinder.

Door Thickness	Cylinder Screw
1-3/4" - 2"	S11
2-1/4"	S12

- Make sure the finger pull is straight and install the S10 self-drilling screw.

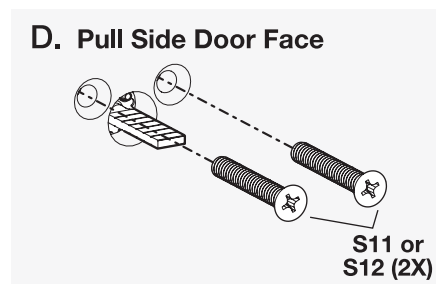
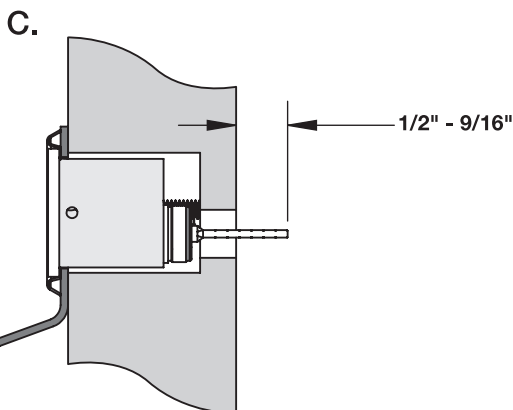
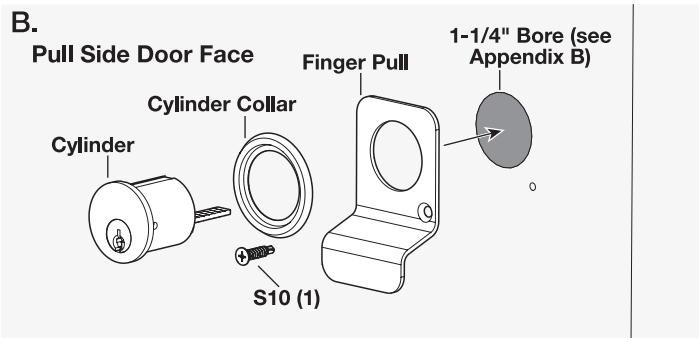
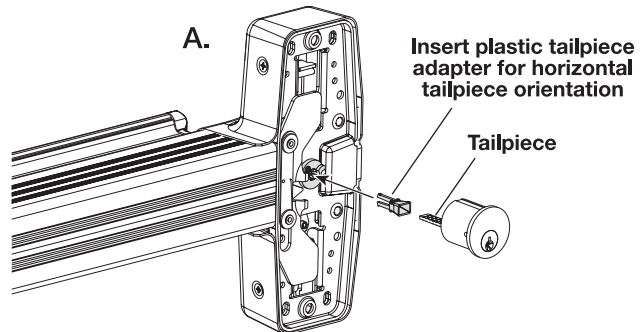

3 REMOVE HEAD COVER

- A. Remove the two rear S15 screws and then remove the head cover.
- B. Remove the front two S15 screws from the head cover and take out the front head cover bracket. Set aside all screws and bracket for later use.

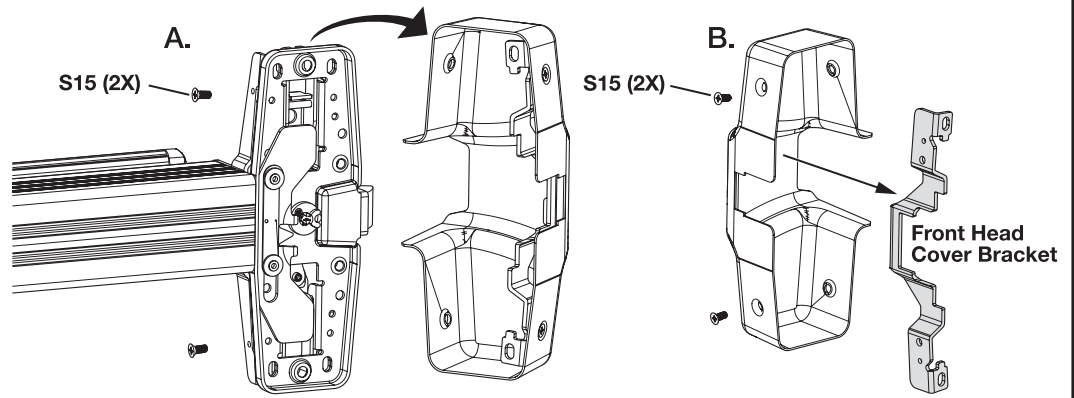

4 INSTALL BODY

- A. Place device body against push side of door. If cylinder is installed, align cylinder tailpiece with tailpiece receiver of device.
- B. Depending on door material, insert one S1 sheet metal screw or S2 machine screw through the upper rear head cover bracket loosely, allowing the device body to rotate.
- C. Using a level, rotate the end of the device until level.
- D. Insert the end cover bracket; mark and drill two holes according to door material.
- E. Reinsert end cover bracket in device and install two S1 or S4 screws according to door material.

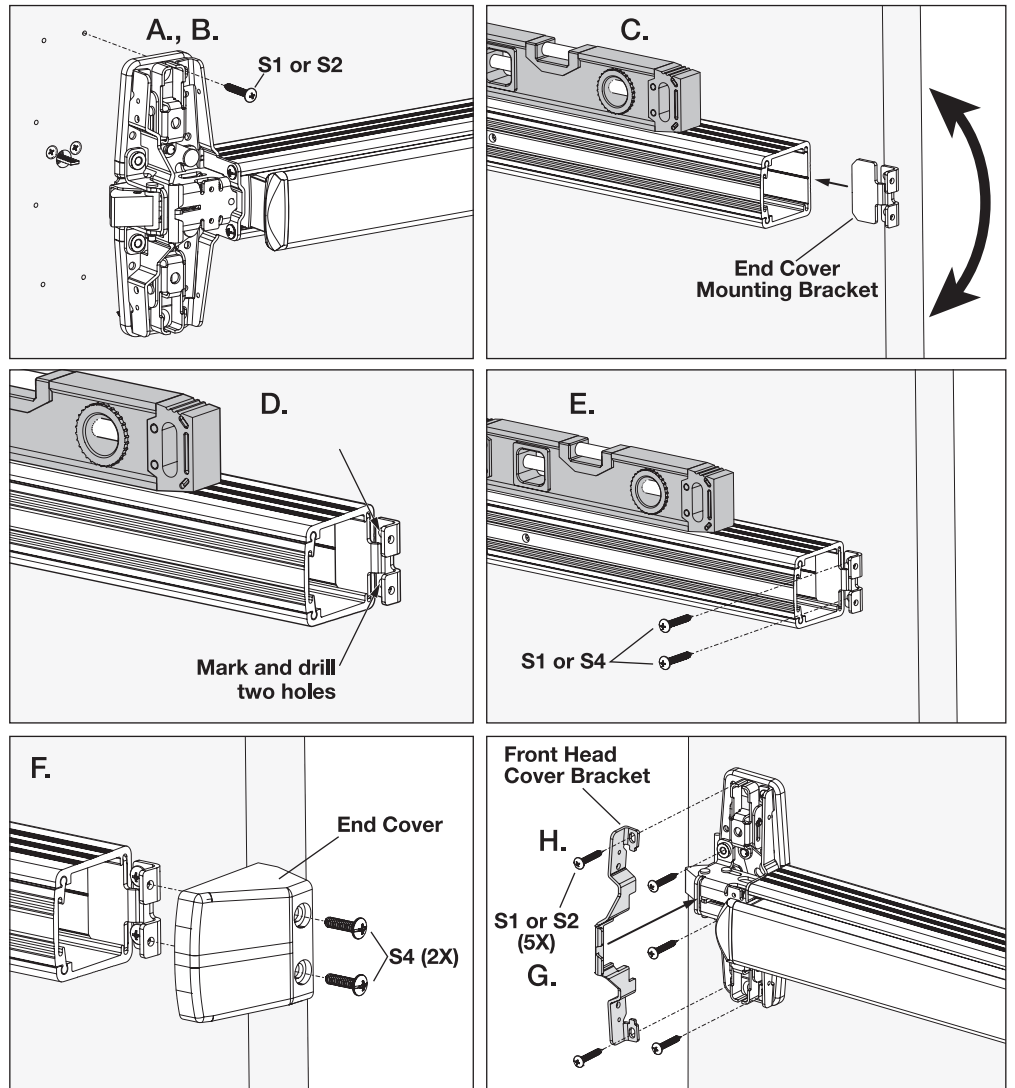

5 INSTALL HEAD COVER

- A. Place the head cover onto the head chassis and align the screw holes with the threaded holes in the brackets.
- B. Secure by inserting four S15 screws (previously removed) and tighten firmly.

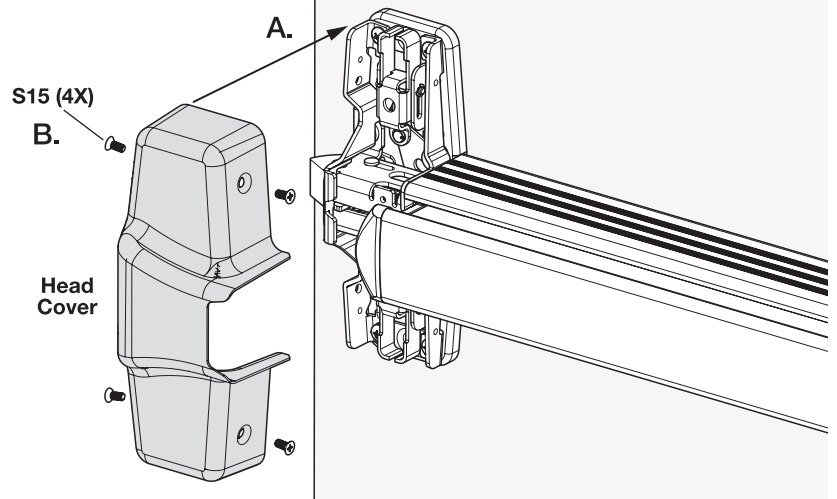

6 INSTALL STRIKE

- With the door open, place strike on the door stop face.
- Align the slots with the marked lines and align the outside edge of the roller with the outside edge of the door stop. Mark three hole-centers and drill holes according to fasteners selected for door frame material.
- Replace strike on door stop face and insert the upper and lower screws, either S13 or S14 depending on fastener selection.

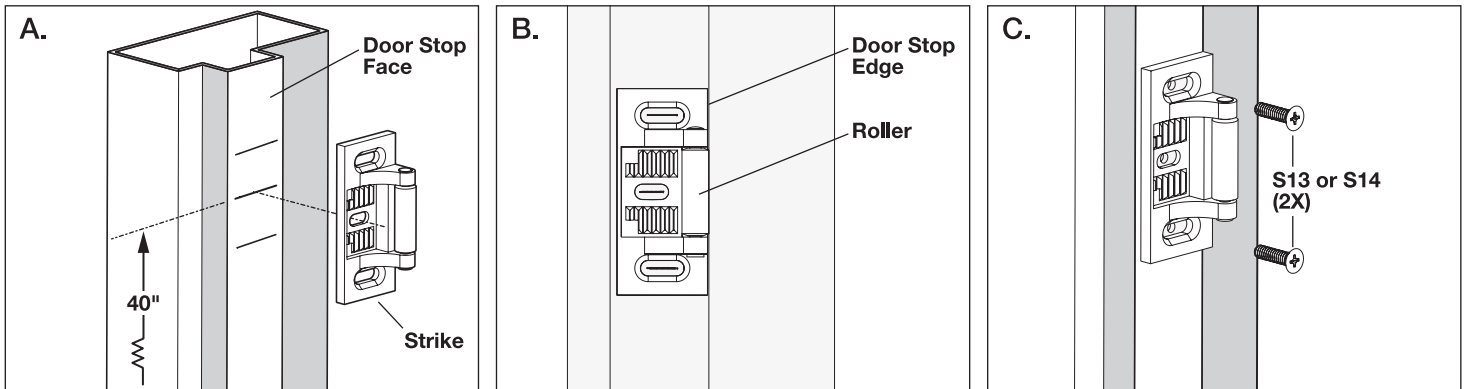

7 OPERATION TEST

- After strike installation, close the door to verify that the latch bolt extends fully, bolt and strike roller have minimal clearance, and the strike and device have the clearance shown.
- To adjust for bolt and strike roller clearance, loosen the two strike screws and adjust the strike left or right as needed. Press down on the push bar and make sure the door opens and closes and latches correctly. If necessary, add the shim.
- When the strike position is confirmed, add the strike support plate and secure with the third strike screw (S13 or S14).

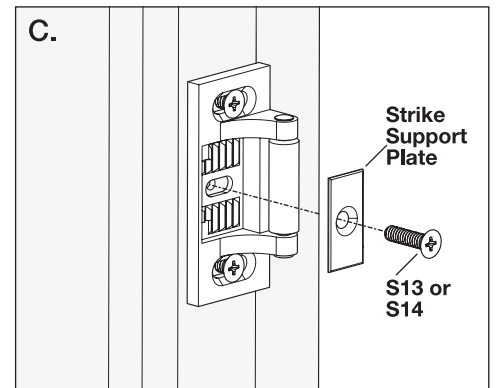
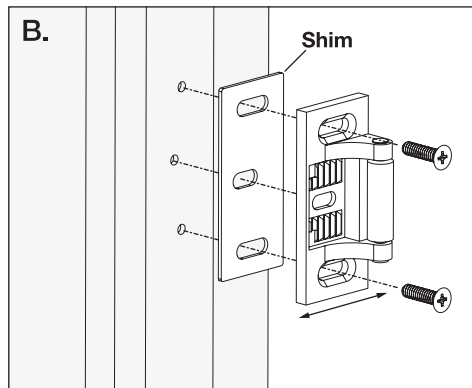
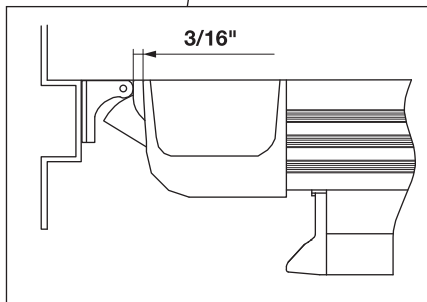

8 DOGGING

To extend the life of this device, lock (dog) the bolt in the retracted position when the door is in continuous use.

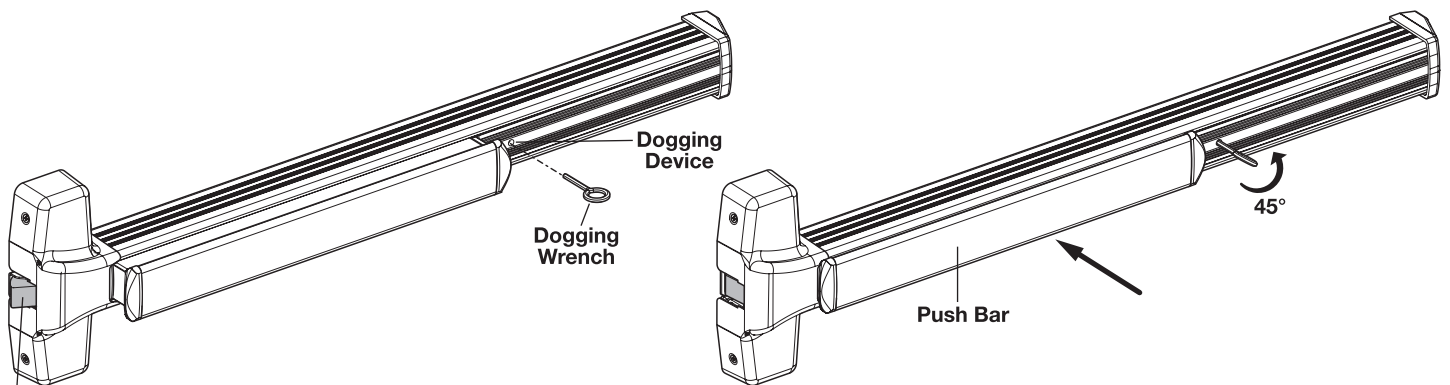

A. TO DOG BOLT: Insert dogging wrench into hole in device. Hold the push bar down and rotate the wrench 45 degrees clockwise.

B. TO RELEASE BOLT: Insert dogging wrench into hole in device. Hold the push bar down and rotate the wrench 45 degrees counter-clockwise.

APPENDIX A — CUTTING DEVICE TO CORRECT LENGTH

- A. Device can be cut down for use on a 28" wide door and requires no modification for a 36" wide door.
- B. Device can be cut down for use on a 30" wide door in a double door + mullion installation.
- C. For doors 28" - 35" wide, use the figure below with the recommended dimensions to determine where to cut the rail and sliding shim.
- D. For doors 28" - 35" wide, tape the sliding shim to the rail to secure the parts and protect the surface. Temporarily remove the anti-rattle clip. Cut at the marked position and deburr carefully. Replace the anti-rattle clip.

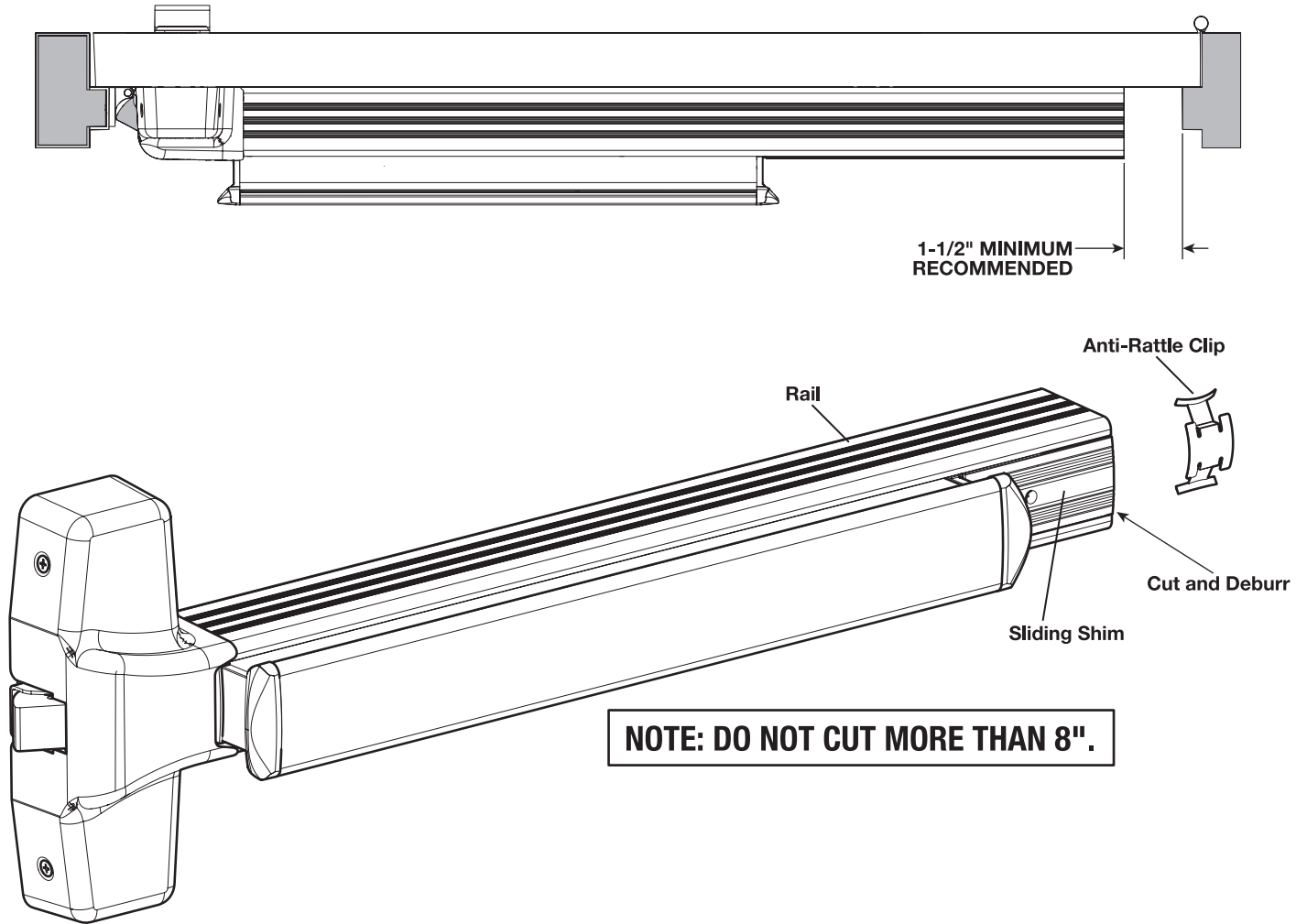

APPENDIX B — HOLE PREPARATION FOR CYLINDER

- A. Mark device center on push side face using template 999-30128. Drill a $\varnothing 1/8"$ hole through the door using a drill bushing to ensure it's straight.
- B. On the pull side door face measure $7/32"$ up from the hole to mark the center of the $\varnothing 1-1/4"$ cylinder hole.
Wood Door: drill $1-3/8"$ deep
Metal Door: drill through one side
- C. On the push side door face, measure $1/4"$ up from the device centerline and mark two screw hole locations.
Wood Door: drill two $\varnothing 13/64"$ holes through to bore. Countersink $\varnothing 3/8" \times 82$ degrees.
Metal Door: drill two holes through one side for countersink tool. Countersink $3/8" \times 82$ degrees.
- D. Cross-section view of the cylinder and tailpiece hole in a wood door.
- E. Cross-section views of the screw hole and countersinks in wood and metal doors.

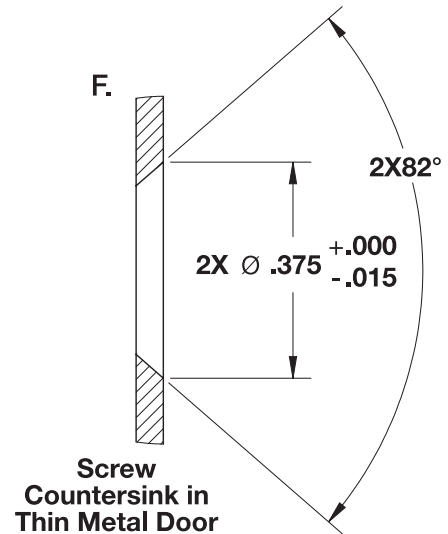
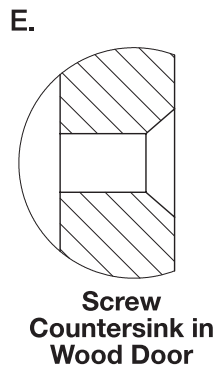
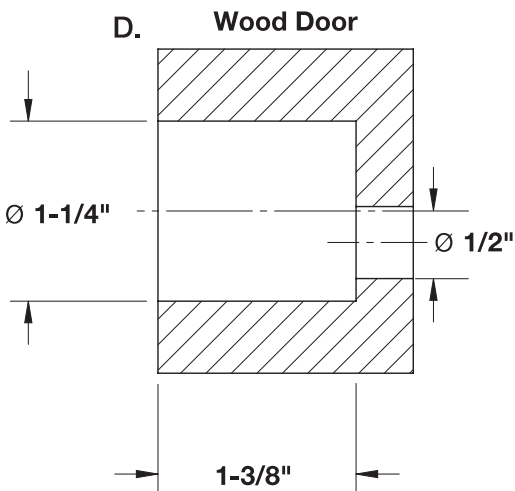
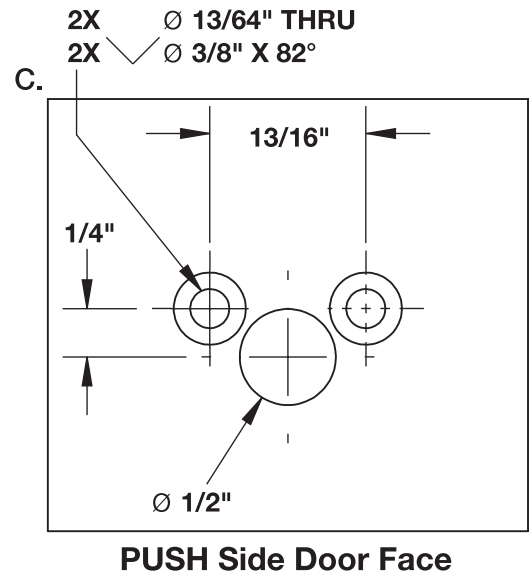
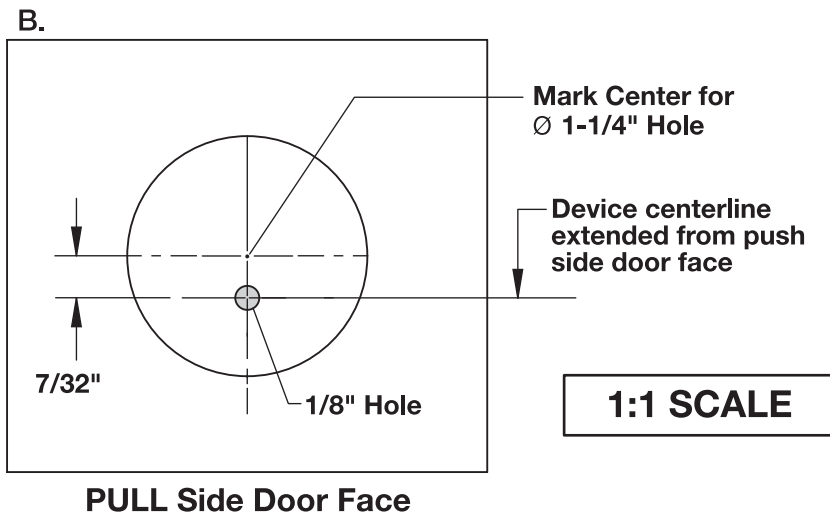
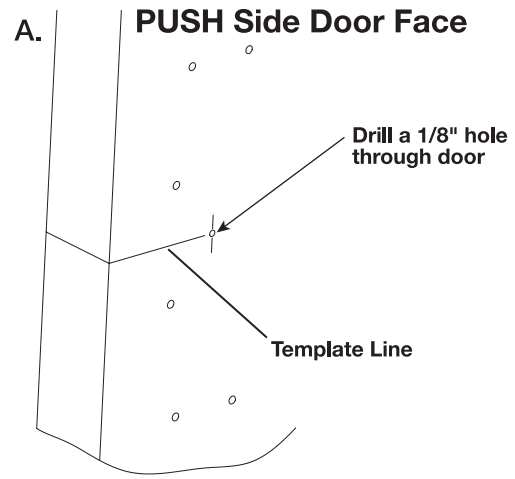

APPENDIX C — HOLE PREPARATION FOR DEVICE

These instructions are supplemental to template 999-30128.

It is recommended to install this device on reinforced steel doors or solid wood doors.

A. Drill 8 holes in door for head chassis and end cover bracket per the instructions below:

For steel reinforced doors, install using six 10-24 x 1" machine screws (S2) for the head chassis, and two 10-24 x 3/4" machine screws (S4) for the end cover bracket.

- Use a #25 (Ø.1495") drill for pilot hole through one side and finish with a 10-24 UNC tap.

For wood doors, install using eight #10 x 1-1/4" self-tapping screws (S1). Drill Ø1/8" holes x 1-1/4" deep.

For thin gauge metal doors, #10 x 1-1/4" (S1) self-tapping screws can be used (but not recommended.) Drill Ø1/8" holes through one side.

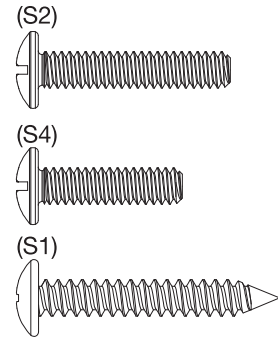

B. Drill 3 holes in door frame for strike per the instructions below:

For metal frames, install using 10-24 x 3/4" machine screws (S13).

- Use a #25 (Ø.1495") drill x 1" deep for pilot hole and finish with a 10-24 UNC tap.

For wood frames, install using #10 x 1-1/2" self-tapping screws (S14). Drill Ø1/8" holes x 1-1/2" deep.

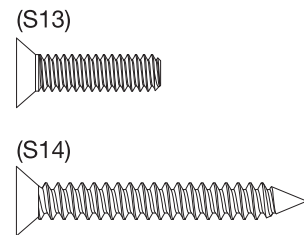

NOTE: For metal doors without proper reinforcement, it is recommended to use through bolts with a length that is close to the thickness of the door. The through bolts are not included but can be used with provided machine screws S1 and S4 for doors up to 2" thick. For doors 2-1/4" thick, used provided machine screws S3 and S5.

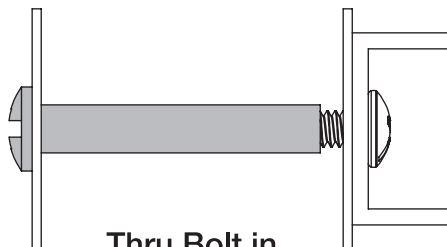

Thru Bolt in
Thin Gauge Door

FULL LIFETIME WARRANTY – Visit www.hampton.care or call 1-866-LOCK-PRO (1-866-562-5776)

WARNING: This product can expose you to chemicals including lead, which is known to the State of California to cause cancer and birth defects or other reproductive harm. For more information go to www.P65Warnings.ca.gov.

©2025 Hampton Products International Corp.
50 Icon, Foothill Ranch, CA 92610-3000 USA
Customer Support: 1-866-LOCK-PRO (1-866-562-5776)
www.hamptonproducts.com
999-30127_M91P REV B 09/25